

DT 100

DIPTANK



FEATURES

- Digital temperature control
- Hydraulic movement
- Stainless steel housing
- Optimal hygiene
- Various dimensions
- Maximal loading capacity: 60 kg
- Machine dimensions: 880 x 1000x 1320mm
- Chamber dimensions: 600 x 800x 220mm
- Dipping depth: 220mm
- Cycle time: 3-5 seconds
- Power: 9,0 kW
- Voltage: 400V-3-50Hz
- Isolation balls prevent evaporation

DESCRIPTION

Combined with a vacuum packaging machine, DT100 produces perfect skin packages for an aesthetic presentation. Shrink technology protects your product like a second skin. This machine fully complies with CE standards.



Henkelman offers standard 3 year warranty

DIPTANK DT 100 – SPECS

DIMENSIONS

In mm

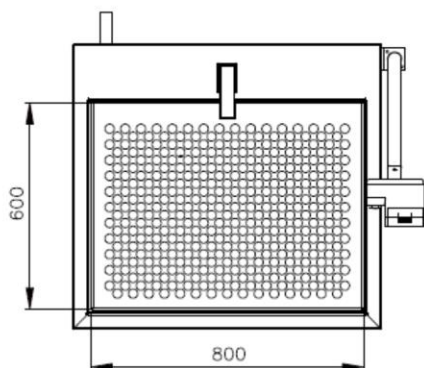

OUTER DIMENSIONS
DT 100

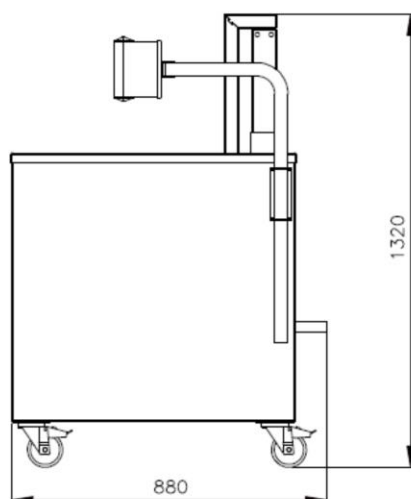
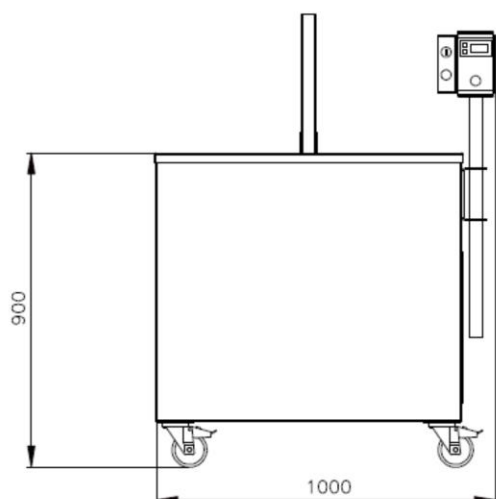

Model	Dimensions (mm)		Voltage (Hz)	Power (kW)	Weight (kg)
	Chamber (usable space) LxWxH	Machine LxWxH			
Diptank DT 100	600x 800x 220	880x 1000x 1320	400V-3-50	9,0	155
* Other voltages available					



HENKELMAN BV
Titaniumlaan 10
5221 CK 's-Hertogenbosch
The Netherlands

Sales support
P +31 73 621 36 71
E info@henkelman.com
Service/technical support
P +31 73 621 36 71
E service@henkelman.com